

Implantation des ferrures de la charpente sur GO (Ech: 1/100)

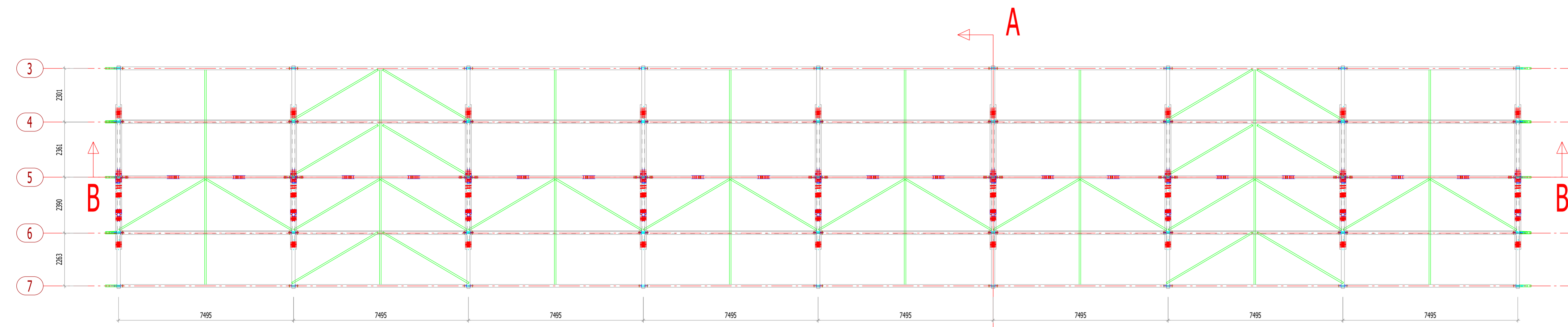

Vue en plan charpente en Z absolu (Ech: 1/100)

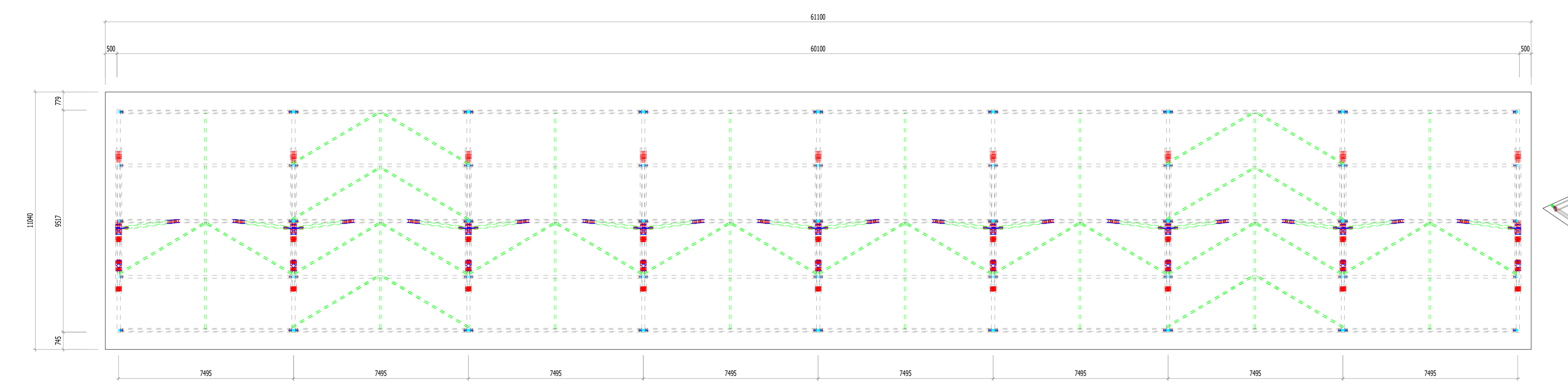

Vue en plan charpente au sens du rampant de couverture (Ech: 1/100)

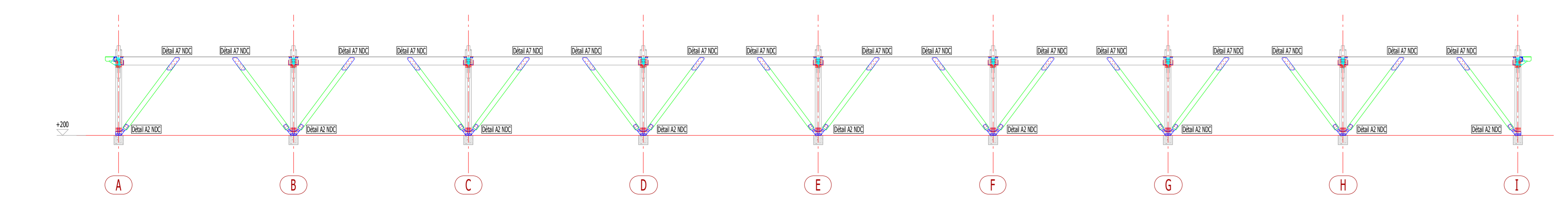

Coupe B-B (Ech: 1/100)

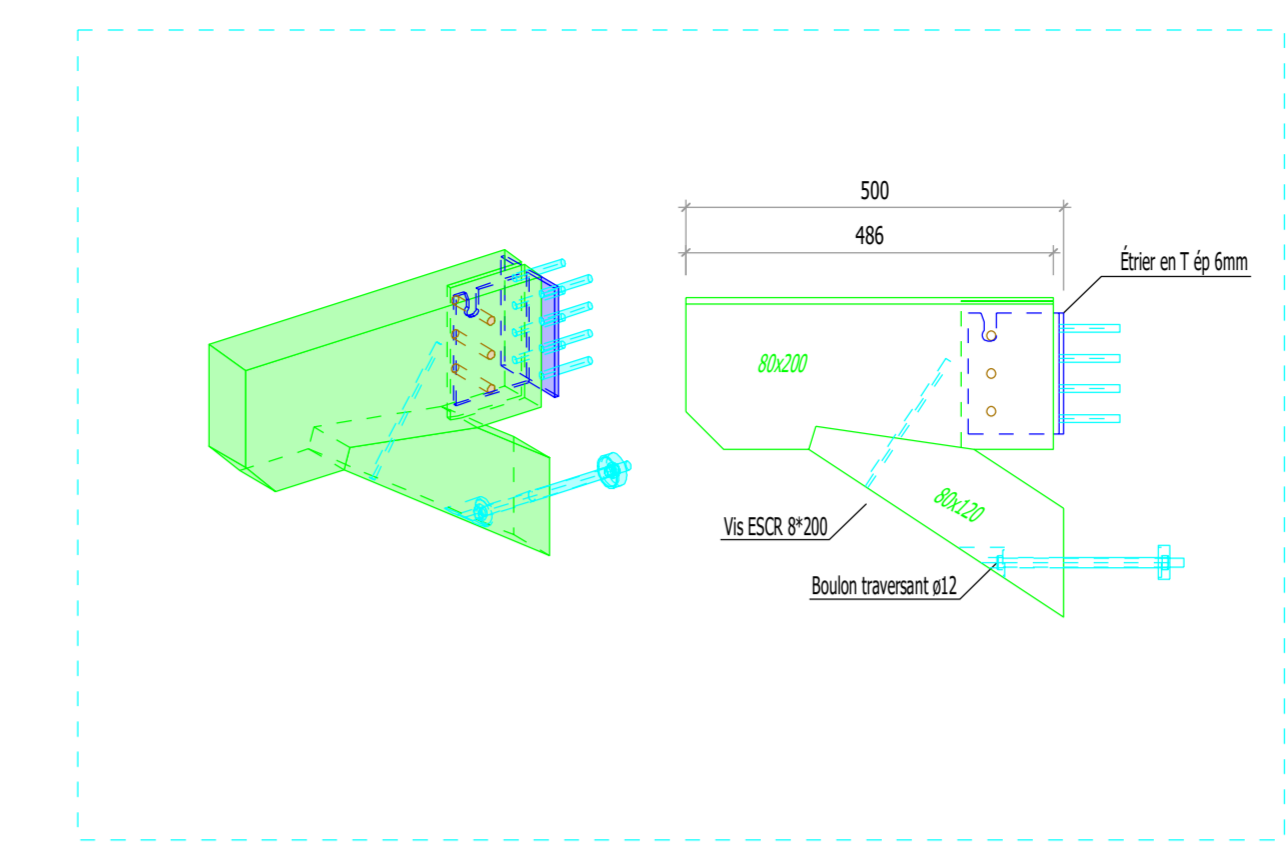

Détail débords

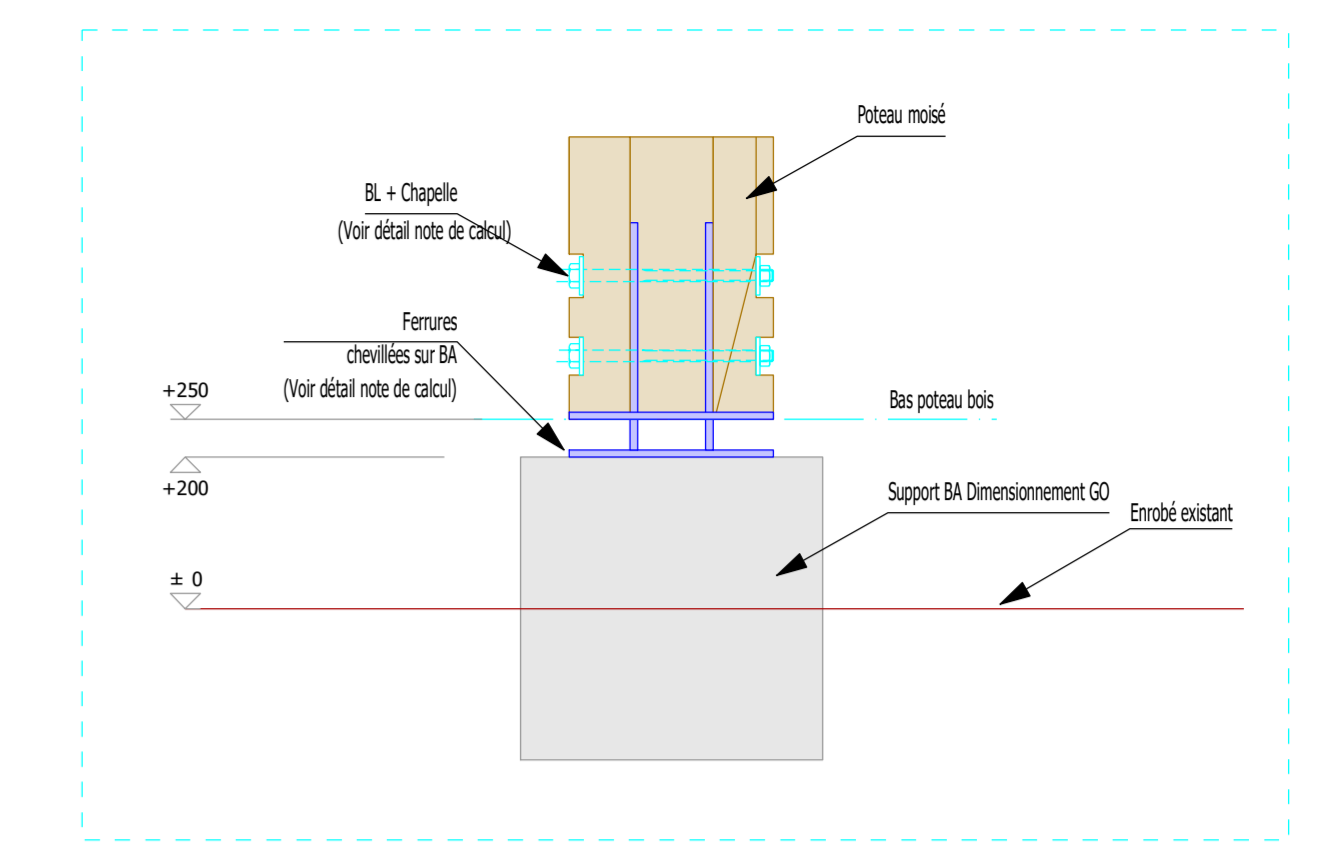

Détail pied de poteau (Ech: 1/10)

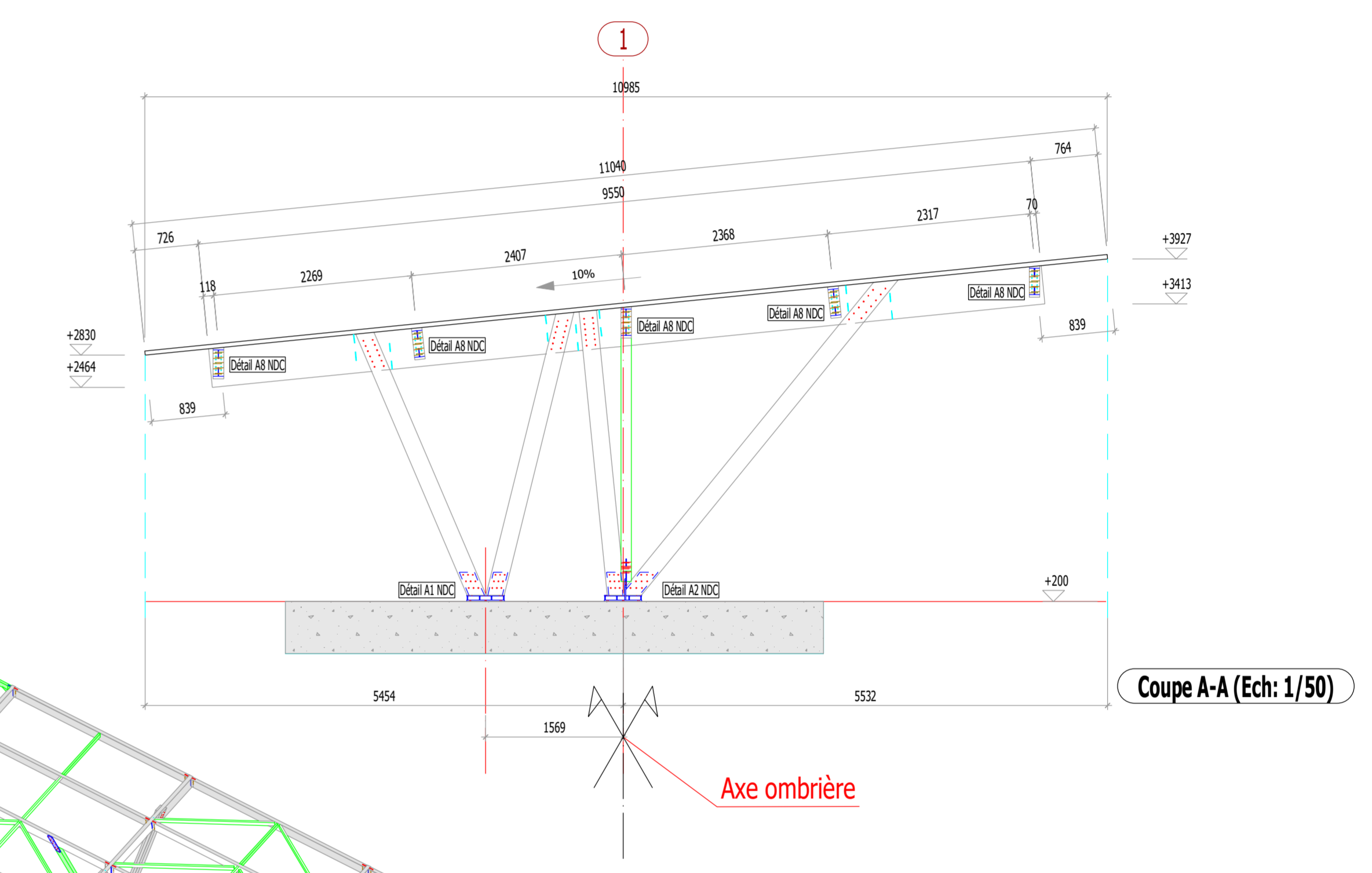

Coupe A-A (Ech: 1/50)

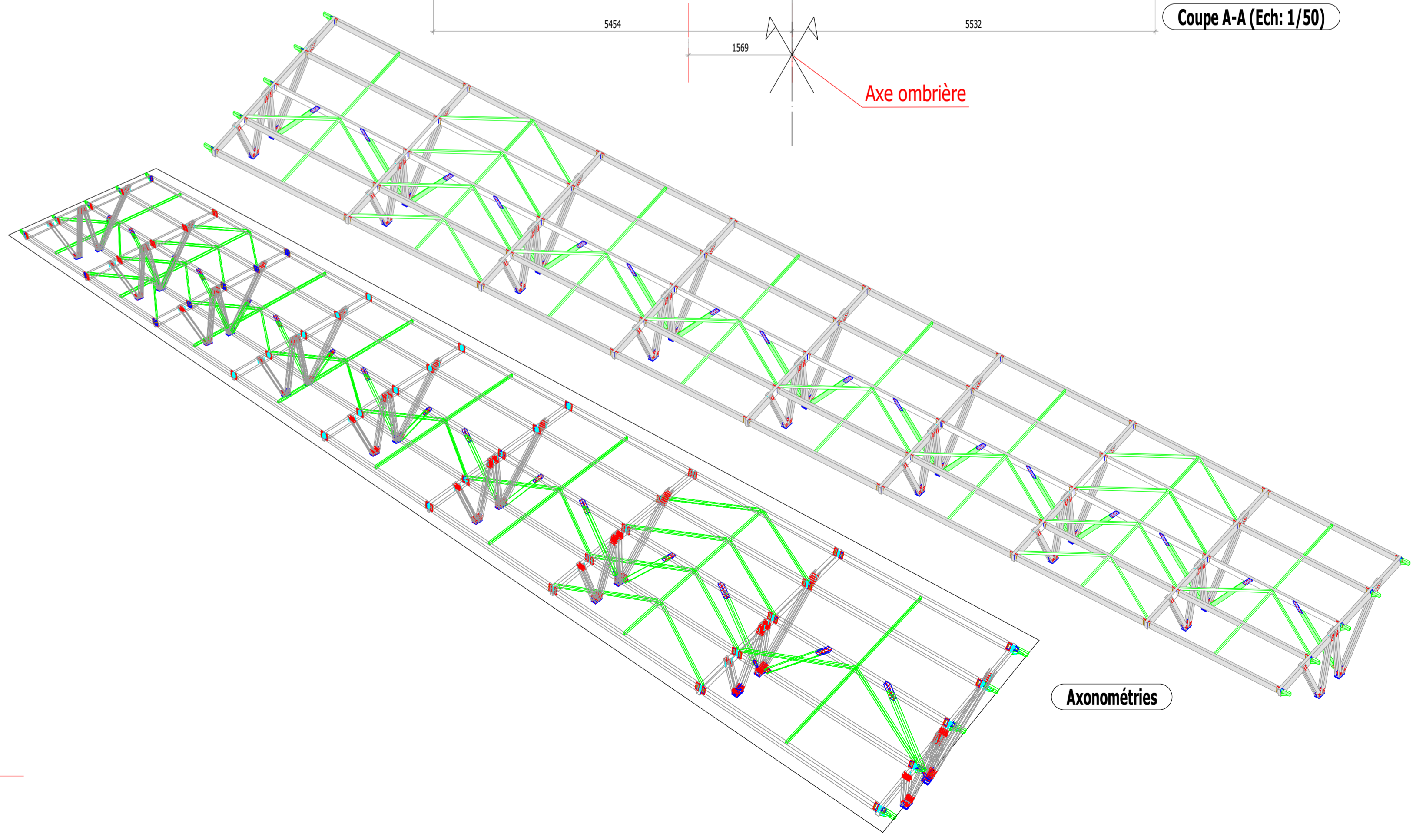

Axonométries

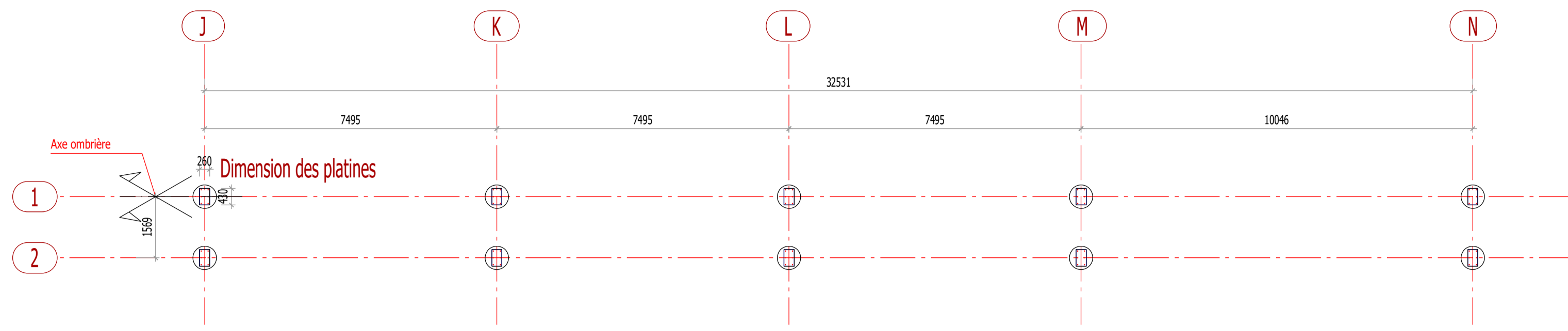

Implantation des ferrures de la charpente sur GO (Ech: 1/100)

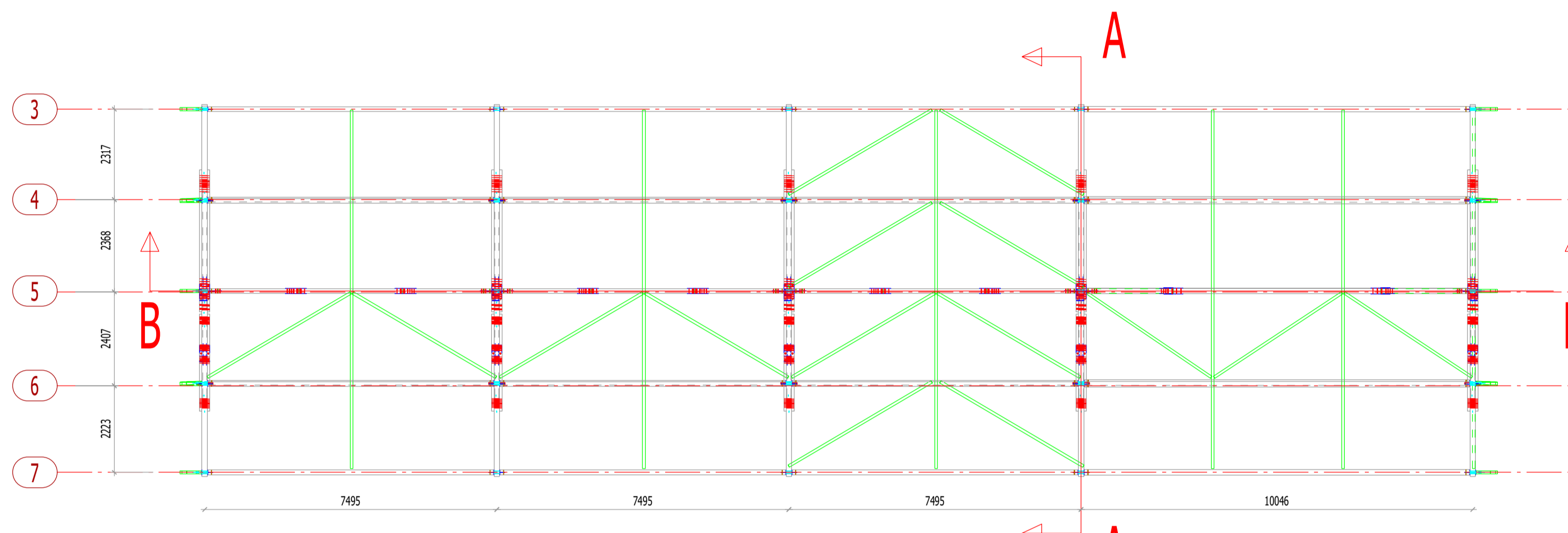

Vue en plan charpente en Z absolu (Ech: 1/100)

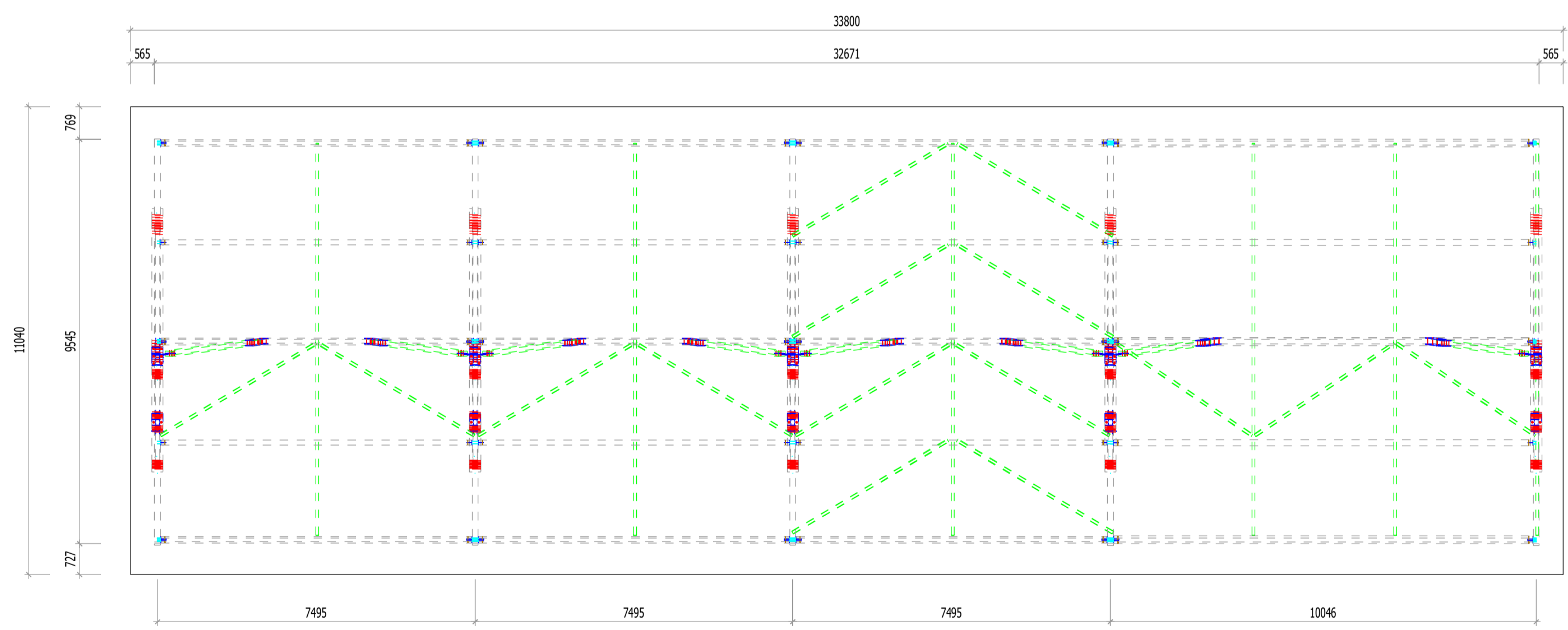

Vue en plan charpente au sens du rampant de couverture (Ech: 1/100)

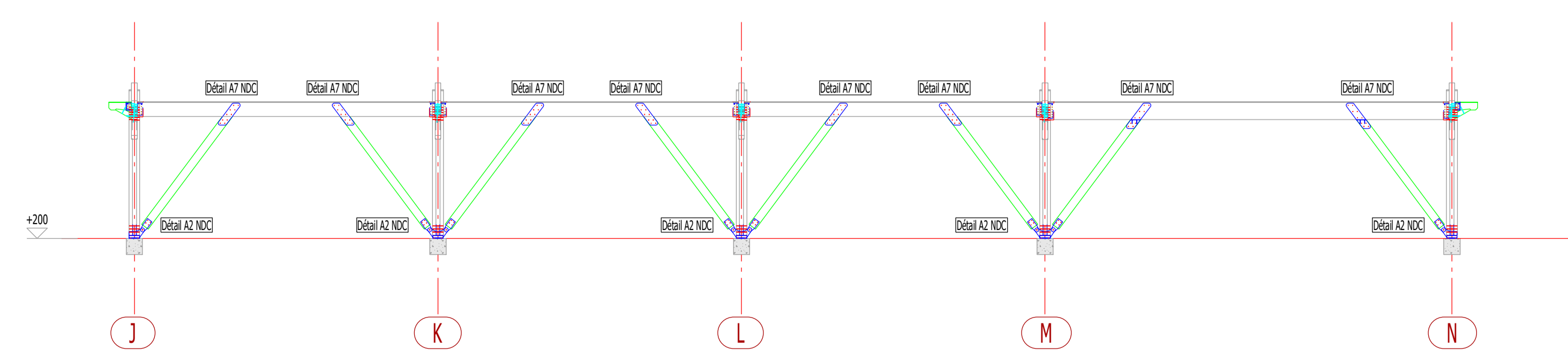

Coupe B-B (Ech: 1/100)

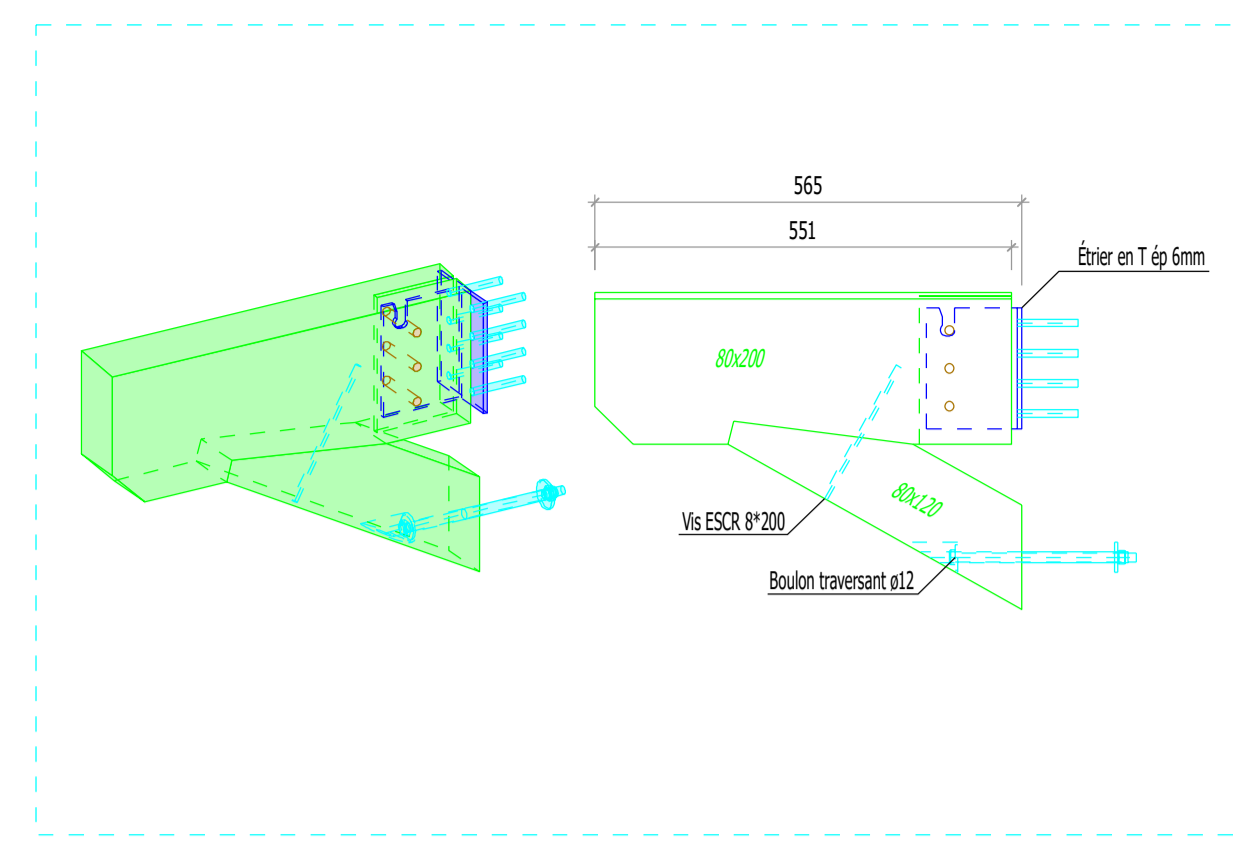

Détail débords

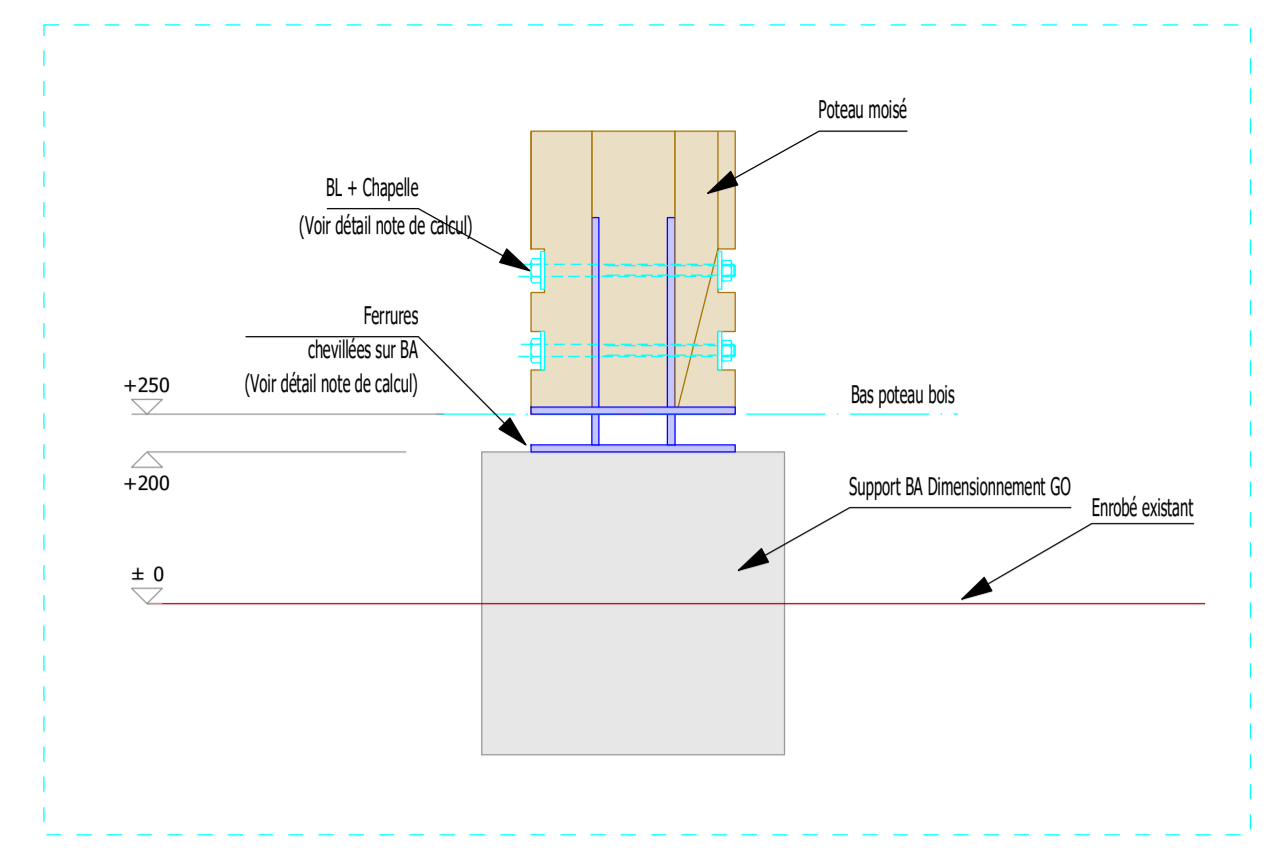

Détail pied de poteau

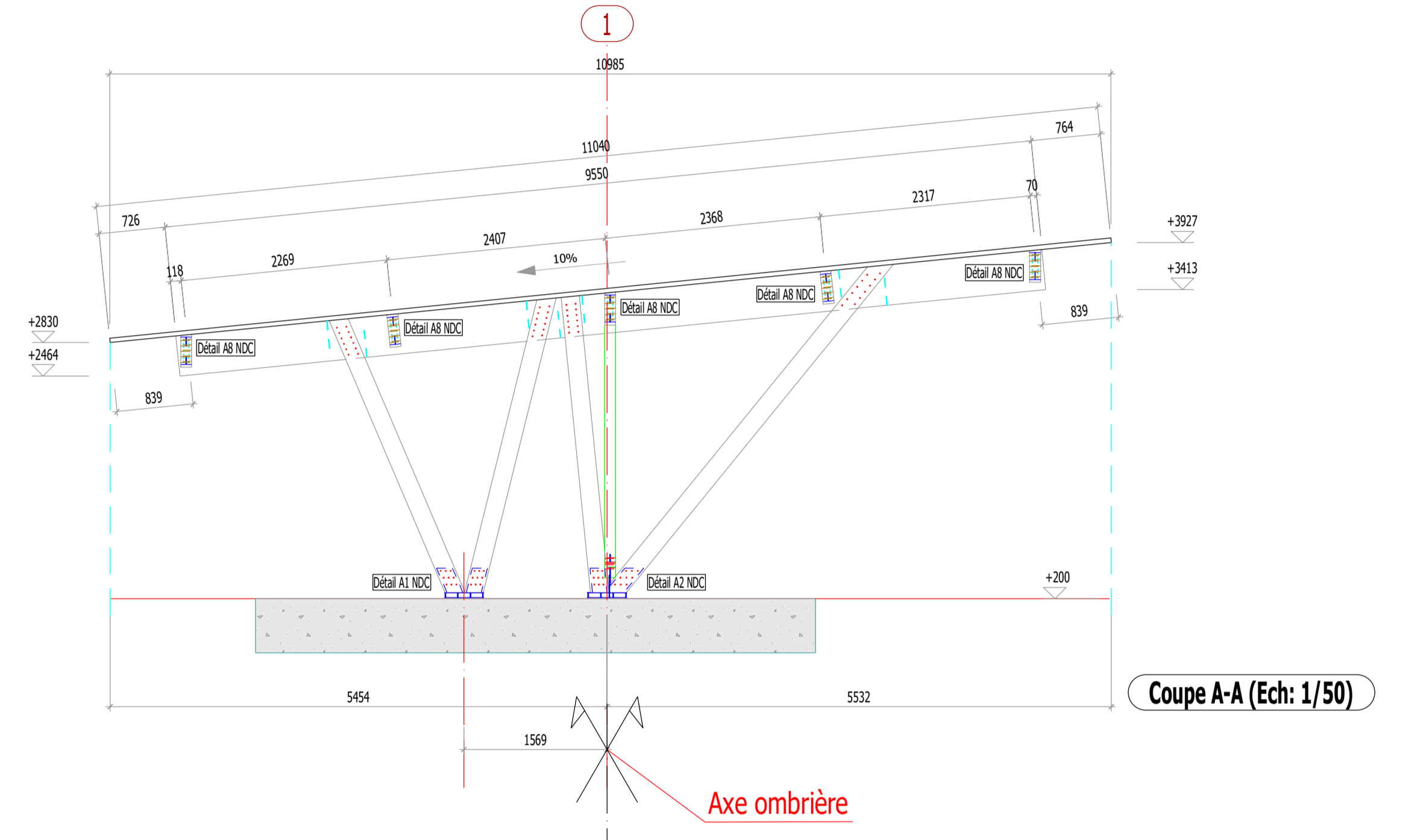

Coupe A-A (Ech: 1/50)

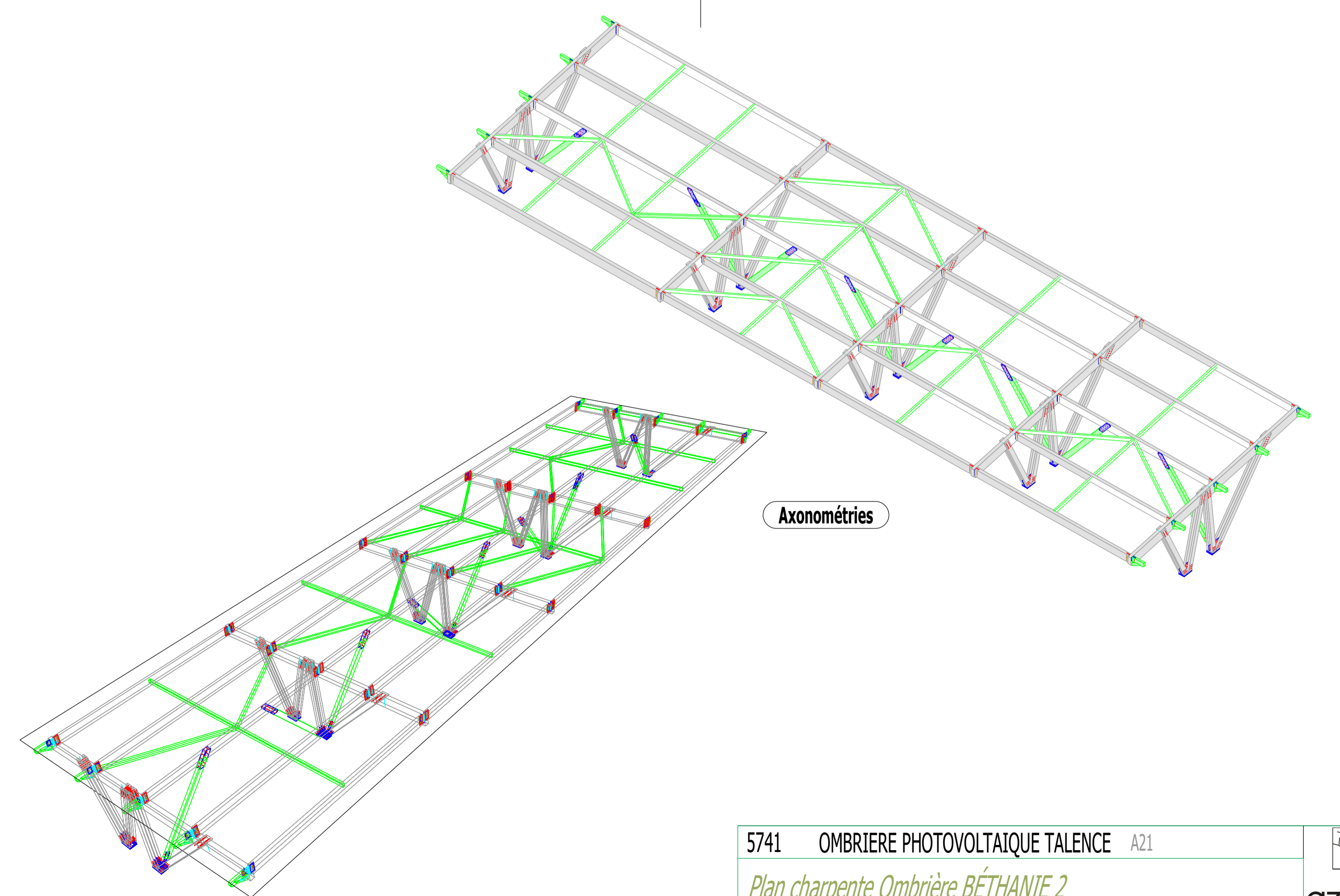

Axonométries