

# TOITURE RUE INTERIEURE

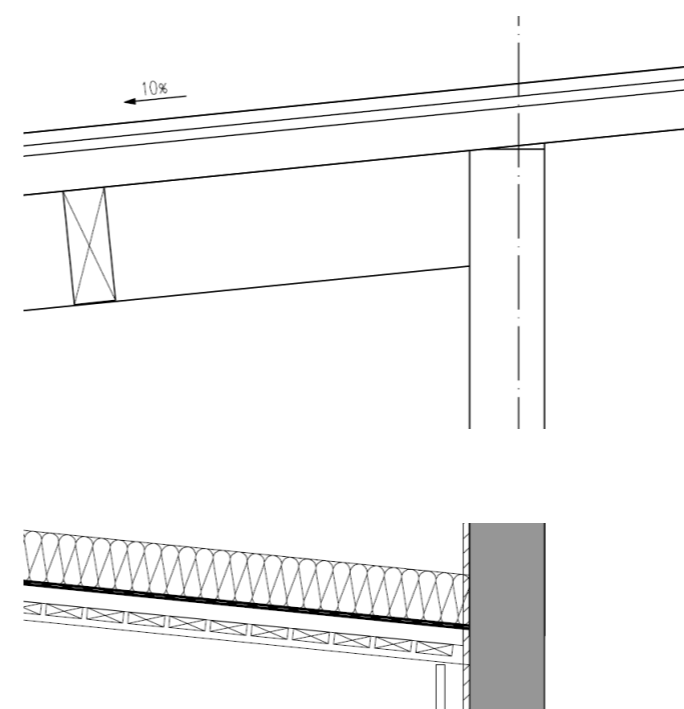

# PORTIQUES RUE INTERIEURE

Détail A6: Assemblage Poteau/Arbalétrier en pignon

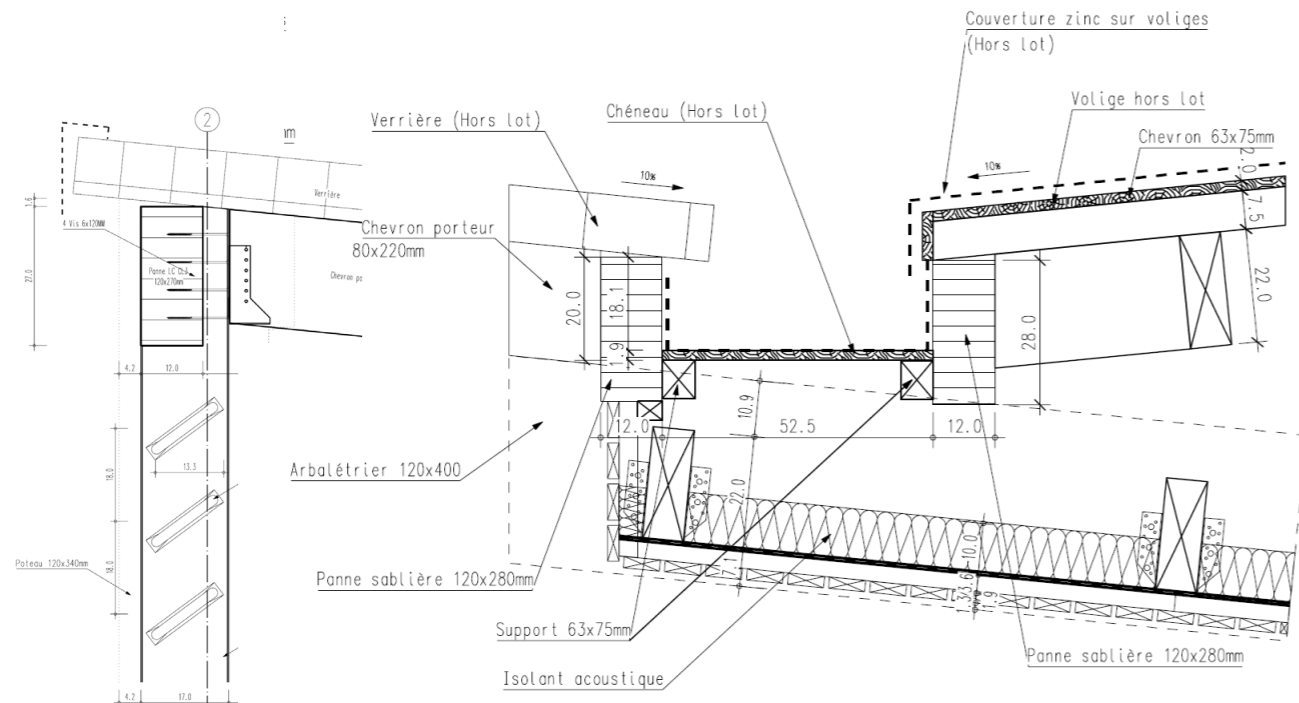
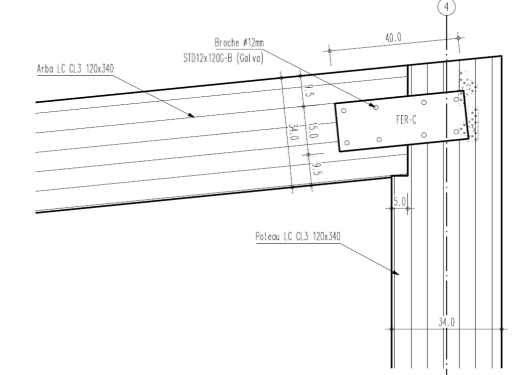

Détail A7: Assemblage Poteau/Arbalétrier courant

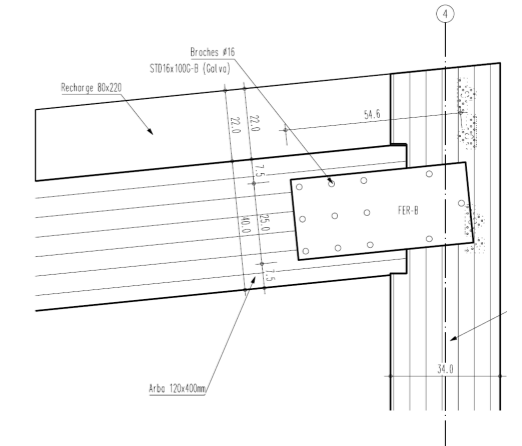

EXT.

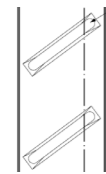

« RUE INTERIEURE »

COURSIVE

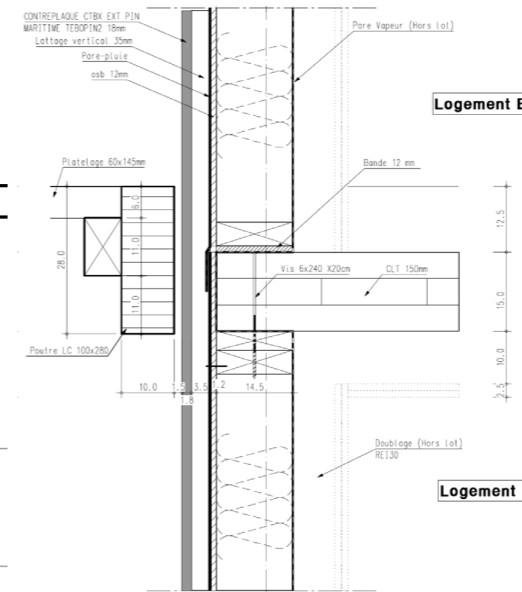
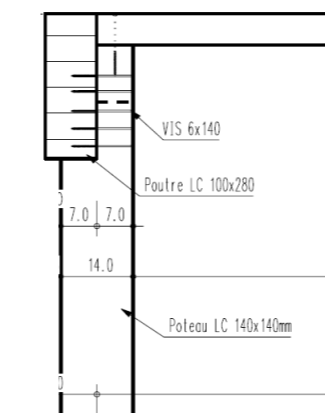

PLANCHER LOGEMENTS

Extérieur

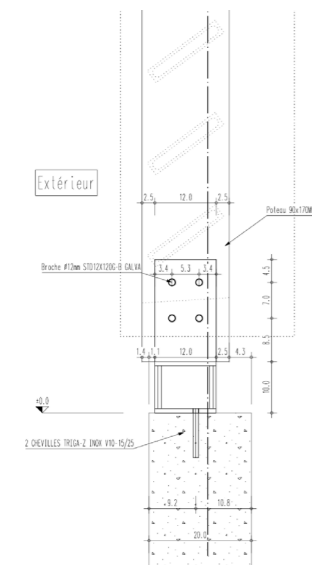

DETAIL EN PIED POTEAUX

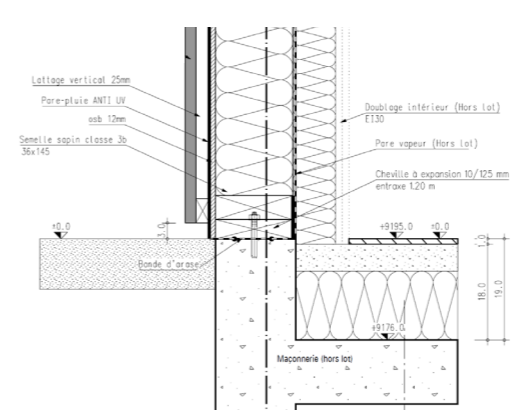
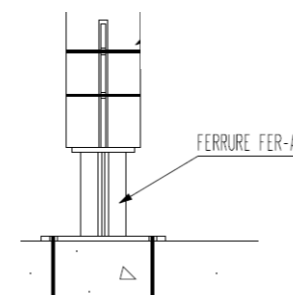

PIED DE FACADE SUR LOGEMENTS