

COUPE CC 1/50

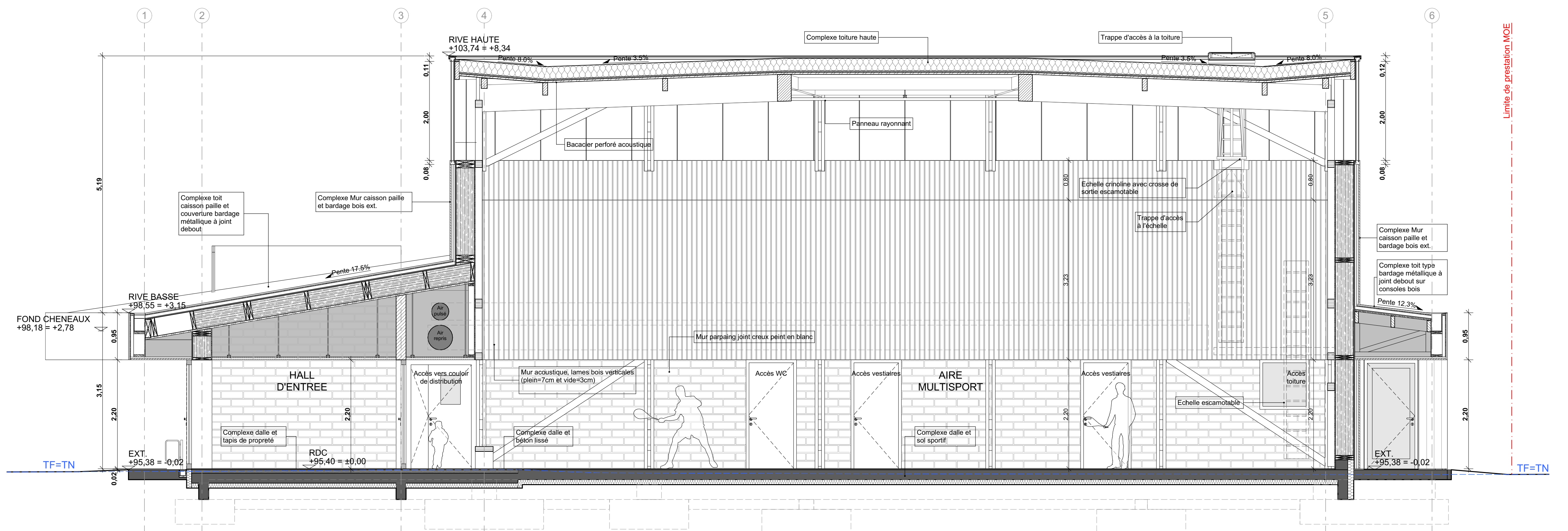

COUPE AA 1/50

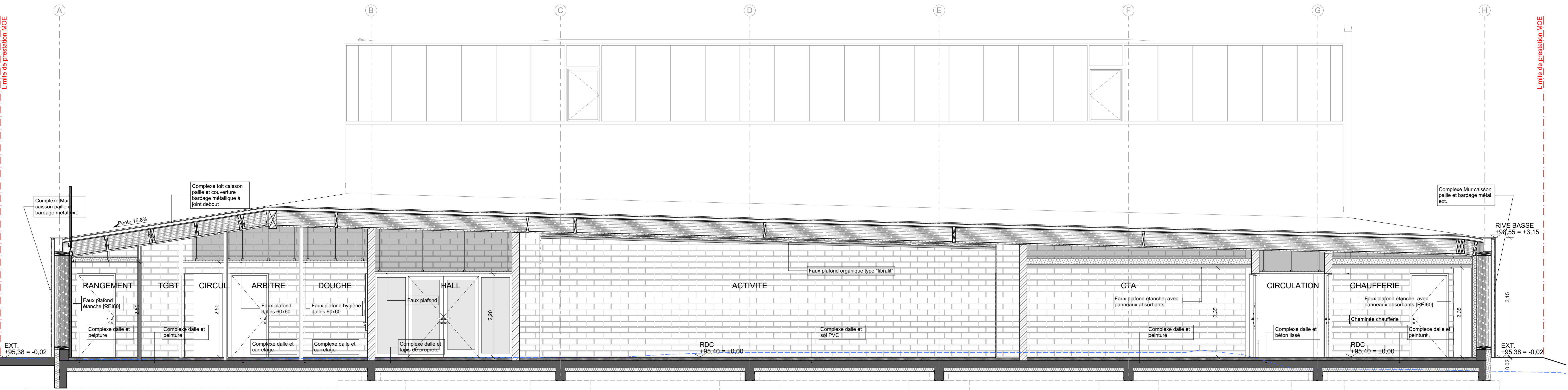

COUPE DD 1/50

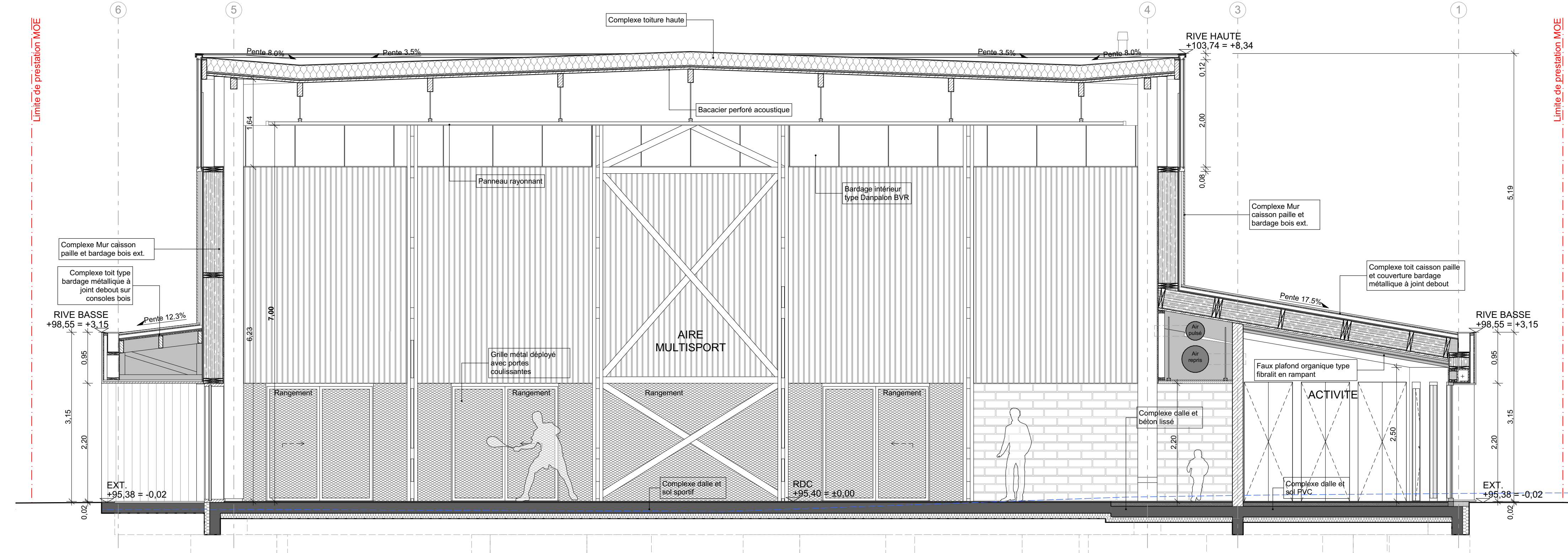

COUPE EE 1/50

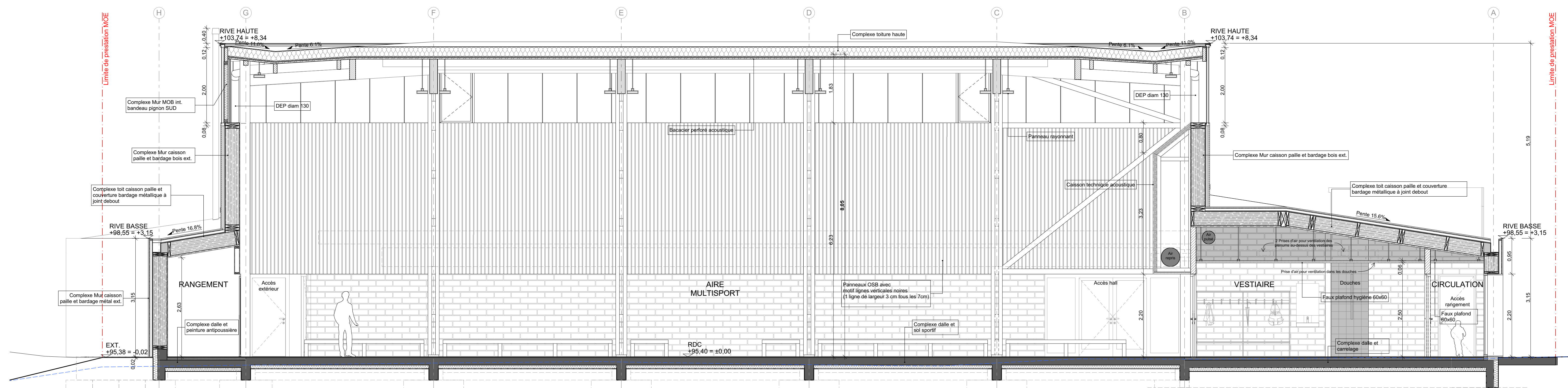

COUPE BB 1/50

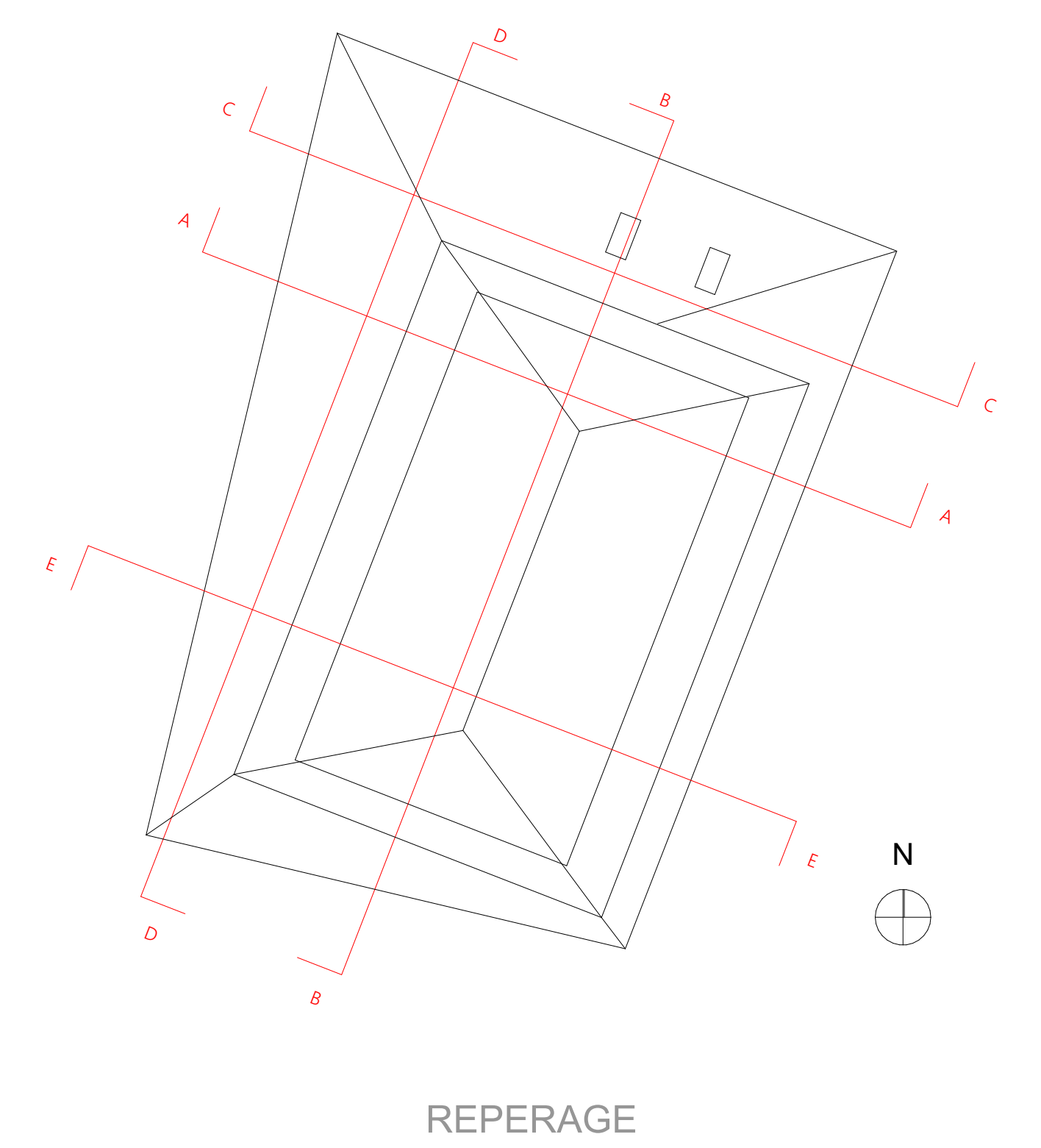

REPERAGE



Construction d'un équipement sportif
A Druye (37)
COUPES - A0+

DCE	ÉCHELLE : 1/50	Edition du	24/01/2020
Indice	Modifications :	PLAN N°	RDC, DCE, MA, A0+
A	<ul style="list-style-type: none"> Niveau des fils d'EP suite à la transmission du relevé géométrique (envi du 19/12/2019) Correction suite aux remarques du RCT (renvi du 24/09/2019) Correction suite aux remarques du SCS (renvi du 13/11/2019) Correction suite aux remarques des services accessibilité PMR 		
Maîtrise d'Ouvrage	Tours Métropole	Email :	v.lavier@tours-metropole.fr 02 47 80 11 79
Bureau de Contrôle	ARIVE	Email :	alice.berthelot@arive.com 02 47 80 48 80
SPS	BATEC	Email :	clotilde.francois@batec-sps.fr 02 47 24 85 15
Maîtrise d'œuvre	Architecte	M'Club Architectes	c.hackel@mcub.eu 01 48 18 08 33
	BE Economiste	Cabinet Gilbert	contact@cabinegilbert.fr 02 38 43 12 74
	BE Structure	Ligne.be	affaires@ligne.be 02 47 75 11 64
	BE Thermique	Maya	max@mayaconcept.com 01 55 28 82 28
	BE Fluides	Maya	max@mayaconcept.com 01 55 28 82 28
	BE Acoustique	Alternative	a.trombet@alternative-consulting.fr 01 44 93 07 74